

Installation Manual

SWT180 Brine-Earth Heat Exchanger

befresh

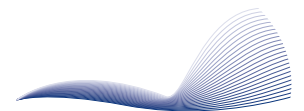

PLUGGIT

Immer frische Luft



PLUGGIT

Immer frische Luft

CONTENTS

1. General safety instructions	2
2. General notes	2
2.1. Intended use	2
3. Installation conditions	2
3.1. Preliminary work by the customer	2
4. Items of the set	3
5. Installation	4
5.1. Installing the SWT180	4
5.2. Connecting the SWT180S controller	6
5.3. Filling the system	6
6. Pressure test	7
7. Removal from service/disposal	7
7.1. Shut-down for removal	7
7.2. Packaging	7
7.3. Old unit	7
8. Technical data	7
8.1. Accessories required	7
8.2. Device data	7
8.3. Dimensions	7
9. Appendices	8
9.1. Pressure drop at SWT180 with G4 filter	8
10. Components to be provided by the customer	9



PLUGGIT

Immer frische Luft

1. GENERAL SAFETY INSTRUCTIONS

Caution:

The following safety instructions should be observed:

- **Read this installation manual thoroughly before beginning with the installation of the SWT180 and putting it into service.**
- **The installation and all electrical work may only be performed by qualified personnel.**
- **Observe all necessary legal and national requirements (accident prevention regulations and approved technical standards) when installing the SWT180 and putting it into service.**
- **No liability whatsoever is assumed for any damage caused by non-product-specific storage, inappropriate installation or improper use.**
- **The technical specifications of this installation manual must be observed to ensure the legal fulfilment of any warranty claims. The warranty is extended to five years if only genuine Pluggit components are used.**
- **Technical modifications reserved.**

2. GENERAL NOTES

2.1. INTENDED USE

The SWT180 can be used to preheat the supplied outside air in winter and precool it in summer.

To do so, the supplied outside air is directed through the heat exchanger of the SWT180 in which a brine mixture (water-antifreeze mixture) circulates.

This allows the utilisation of the higher earth temperature in order to heat the outside air and ensure frost-proof operation of the ventilation unit in winter.

In summer the cooler earth temperature is used to pre-cool the outside air.

3. INSTALLATION CONDITIONS

3.1. PRELIMINARY WORK BY THE CUSTOMER

- Determine a suitable location for the SWT180:
 - Vibration-free
 - Water-protected
 - Free from variations in temperature
 - Nearby the ventilation unit
 - With accessible connections for maintenance work
- Install the PE pipes for the brine lines in the earth. See page 9 for the components required.
- Create water-tight wall ducts for the outer air supply and brine lines.
- Create a condensate drain.
- Install the electrical connection with 230 V for the SWT180S controller.

Note:

All permits, laws and rules required can be found in the product information.



PLUGGIT

Immer frische Luft

4. ITEMS OF THE SET

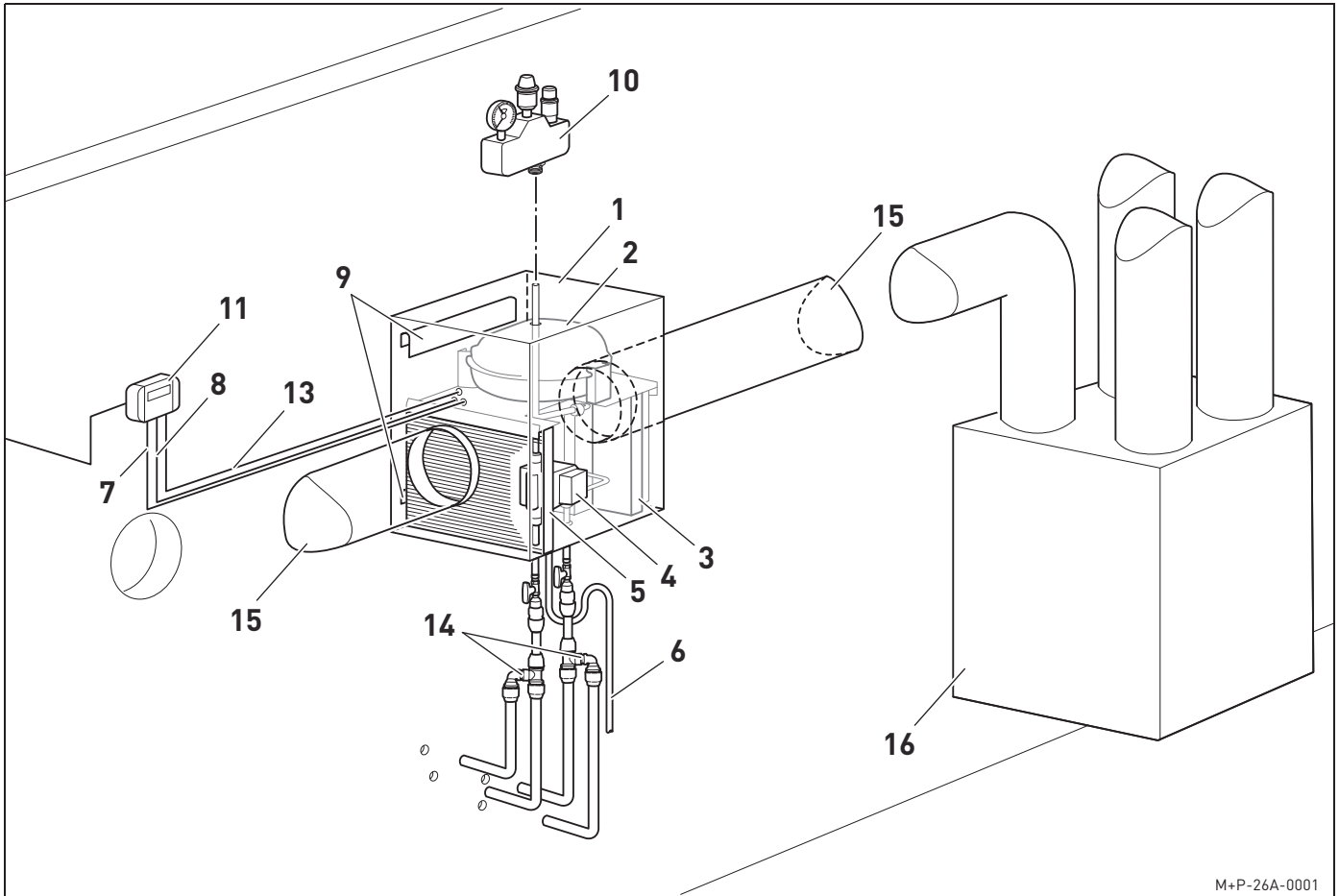

SWT180 Pluggit brine-earth heat exchanger

- 1 SWT180
- 2 Expansion vessel
- 3 Heat exchanger
- 4 Circulation pump
- 5 Filter of G4 quality
- 6 Condensate line
- 7 Temperature sensor (A)
- 8 Temperature sensor (I)
- 9 Mounting bracket
- 10 Safety assembly

SWT180S controller

- 11 SWT180S controller
- 12 SWT180S controller connection
- 13 Circulation pump connection

Accessories required

- 14 Components to be provided by the customer (see page 9)
- 15 Ventilation pipes (see page 7)
- 16 Avent P300, Avent P300N or Avent P450
Pluggit ventilation unit



PLUGGIT

Immer frische Luft

5. INSTALLATION

5.1. INSTALLING THE SWT180

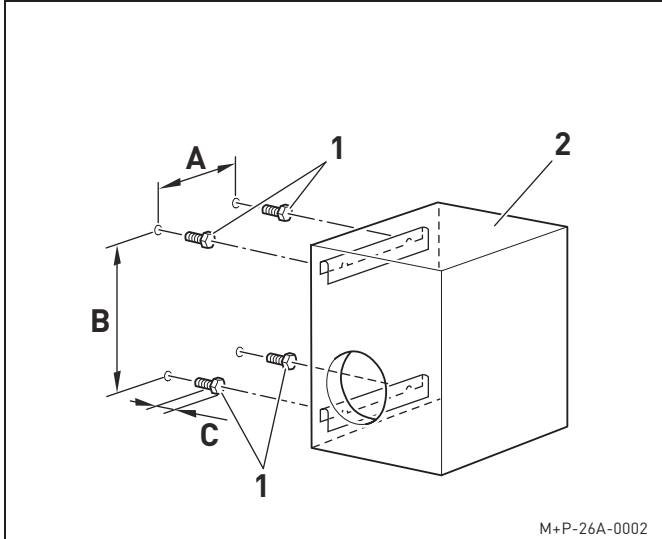

M+P-26A-0002

1. Drill holes as illustrated here and screw in the screws (1) M6x60 DIN 7976.
A 300 mm
B 385 mm
C 3 mm
2. Hook in the SWT180 (2).



PLUGGIT

Immer frische Luft

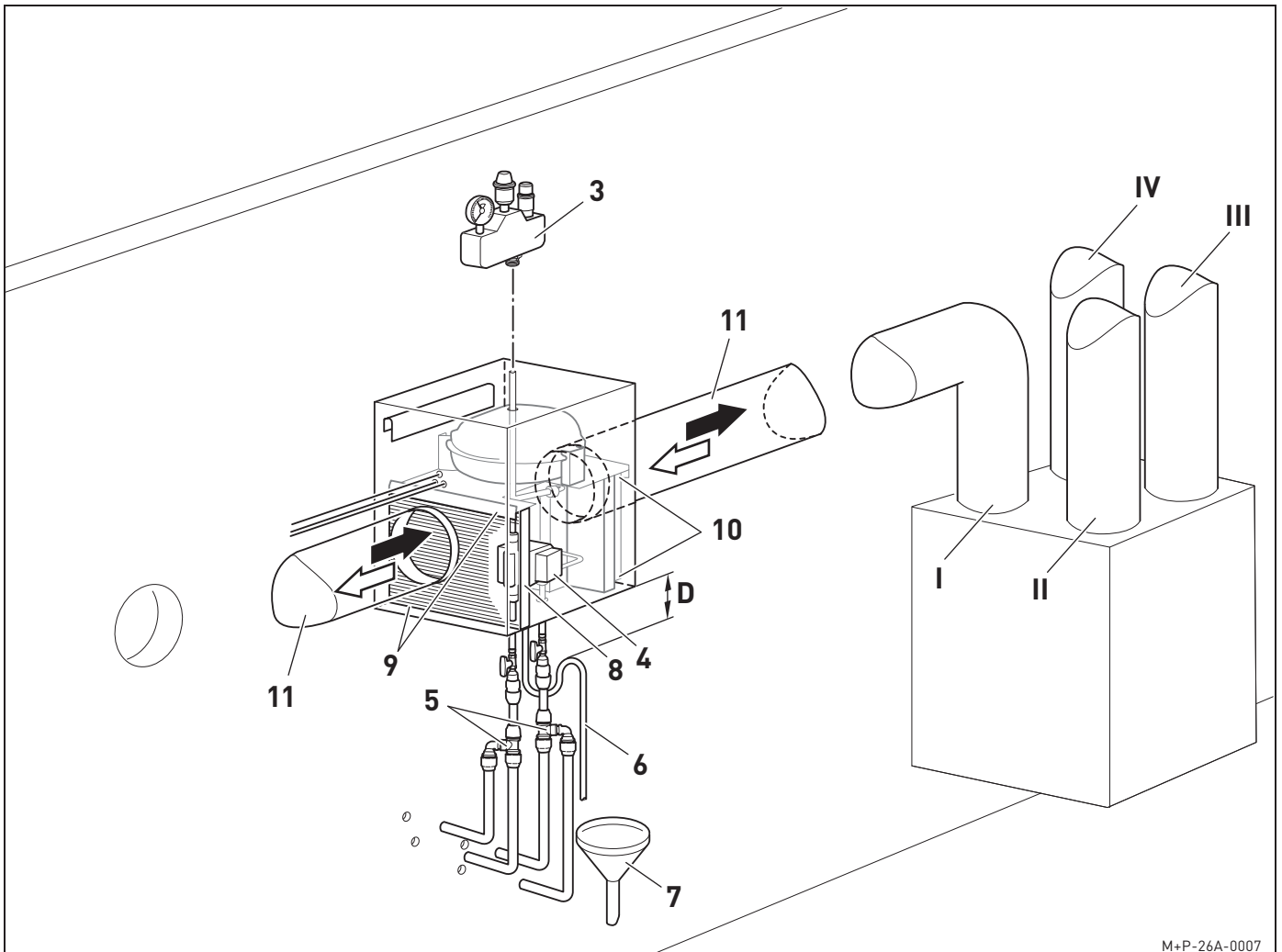

M+P-26A-0007

3. Connect the safety assembly (3) in a professional manner.
4. Wire the circulation pump (4).
5. Connect the brine lines (5).
6. Fasten the condensate line (6).
7. Put the condensate line (6) in a siphon loop into a funnel (7) or siphon.
Observe a minimum drain height (D) of the condensate of 100 mm.
8. Insert the filter (8) on the outside air intake side.
➔ flow direction:
Insert the filter (8) in holders (9).
⇐ flow direction:
Insert the filter (8) in holders (10).

9. Install the ventilation pipes (11) in a professional manner.
I Outside air (AU)
II Exhaust air (AB)
III Supply air (ZU)
IV Outgoing air (FO)

Note:

The following sections of the technical manual must be observed for the installation of the ventilation pipes:

- Heat insulation and protection against the formation of condensation
- IsoPlugg insulation pipe and moulded parts
- Fitting and operation – IsoPlugg insulation pipe



PLUGGIT

Immer frische Luft

5.2. CONNECTING THE SWT180S CONTROLLER

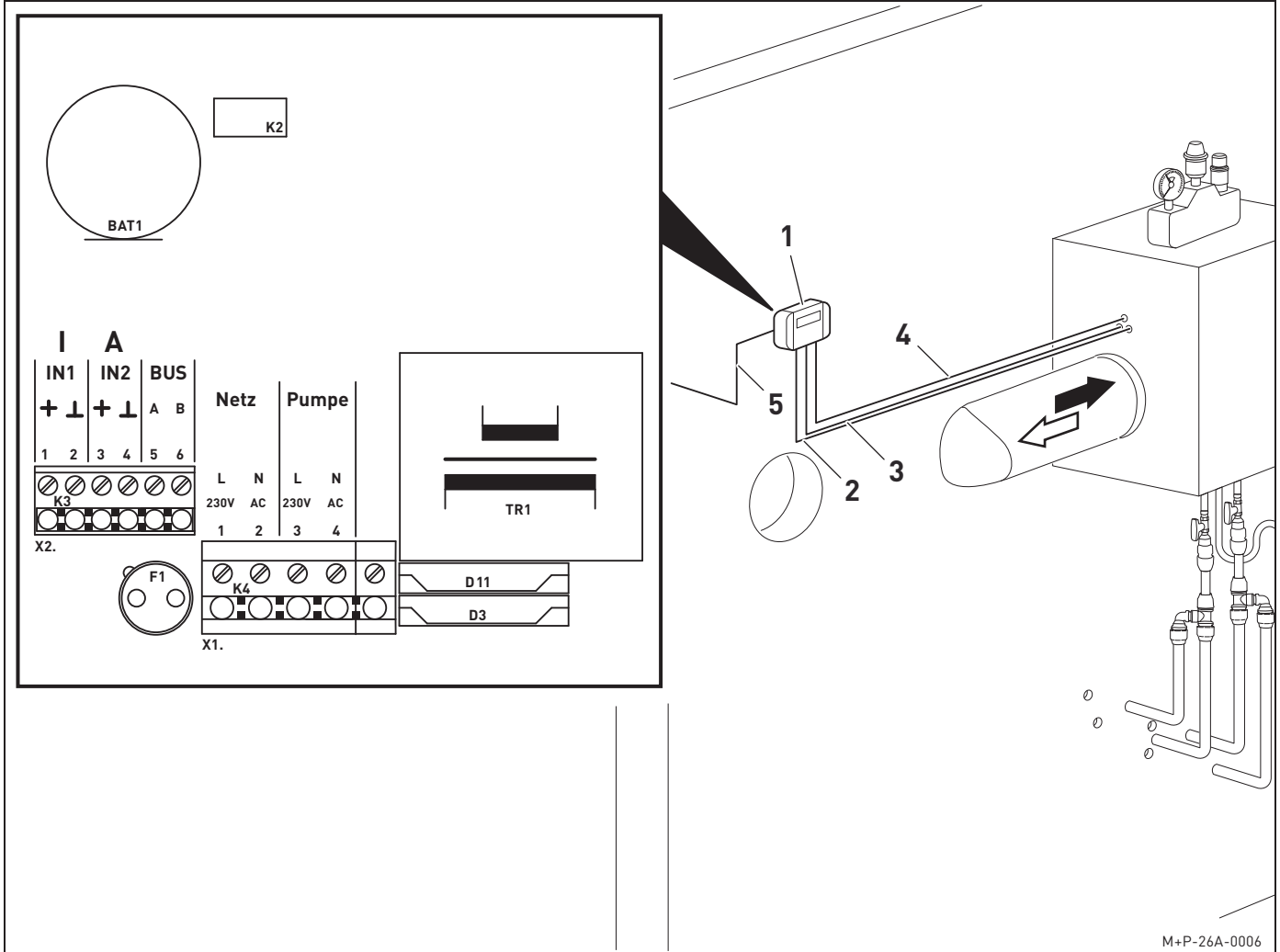

- IN1 terminal for temperature sensor (I)
 - IN2 terminal for temperature sensor (A)
 - Bus terminal
 - Mains terminal (line cross-section of $3 \times 1.5 \text{ mm}^2$)
 - Pump terminal (line cross-section of $3 \times 0.75 \text{ mm}^2$)
1. Fasten the SWT180S controller (1).
 2. Connect temperature sensor A (2) to the IN2 terminal downstream of the heat exchanger \leftarrow in the direction of flow.
 3. Connect temperature sensor I (3) to the IN1 terminal upstream of the heat exchanger \rightarrow in the direction of flow.
 4. Connect the circulation pump (4) to the pump terminal.
 5. Connect the SWT180S controller (5) to the mains terminal.

5.3. FILLING THE SYSTEM

Note:

Observe sufficient mixing proportions of the brine mixture. Frost protection must be ensured at approx. $-18 \text{ }^\circ\text{C}$.

1. Fill the system with approx. 60 litres of brine mixture.
2. Bleed the brine lines in a professional manner after filling the system.
3. Pressurise the system with approx. 1.5 - 2.0 bar.



PLUGGIT

Immer frische Luft

6. PRESSURE TEST

The system must be subjected to a pressure test in compliance with DIN EN 805 or the DVGW (German Gas and Water Society) work sheet W 400-2 before putting it into service after installing it.

The pressure test should be conducted only by qualified personnel with expertise in conducting such pressure tests, in the testing methods and in the required safety regulations.

7. REMOVAL FROM SERVICE/DISPOSAL

7.1. SHUT-DOWN FOR REMOVAL

The system may be removed from service only by qualified personnel.

- De-energise the system.
- Disconnect the entire system from the mains supply.

7.2. PACKAGING

The transport and protective packaging is made largely of reusable materials.

All packaging materials should be disposed of according to local regulations.

7.3. OLD UNIT

The SWT180 and SWT180S controller also contain valuable materials and substances which should not end up in the residual waste.

Hand over old units to a local recycling plant for recycling.

8. TECHNICAL DATA

8.1. ACCESSORIES REQUIRED

- Screws (M6x60 DIN 7976) for mounting bracket
- SWT180S controller for Pluggit SWT180 brine-earth heat exchanger
- IsoPlugg ventilation pipes, IP150 or IP180 insulation pipe
- Components to be provided by the customer (see page 9)
- Optional filter of F7 filter quality

8.2. DEVICE DATA

Weight	35 kg
Connection for ventilations pipes	<ul style="list-style-type: none"> • IsoPlugg IP150 or IP180 insulation pipes • Standard vapour diffusion-tight insulated pipes with d 150 mm or 180 mm
Connection for brine lines	15 x 1 mm copper pipe
Air flow rate	max. 330 m ³ /h
Brine delivery rate	150 - 200 litres/h
Operating pressure	1.5 - 2.0 bar
Filter	G4 filter quality Optionally available in F7 filter quality.

8.3. DIMENSIONS

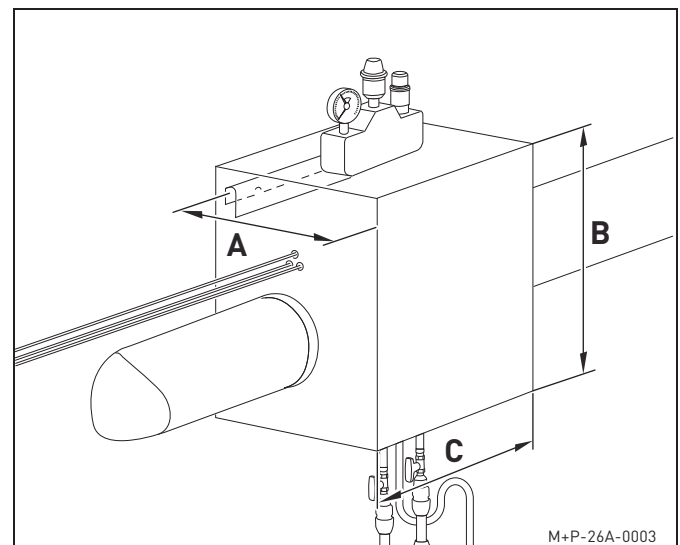

A	Total width	420 mm
B	Total height	480 mm
C	Total length	504 mm

Note:

Keep an additional clearance of approx. 500 mm around the SWT180 for connections and subsequent maintenance work.



PLUGGIT

Immer frische Luft

9. APPENDICES

9.1. PRESSURE DROP AT SWT180 WITH G4 FILTER

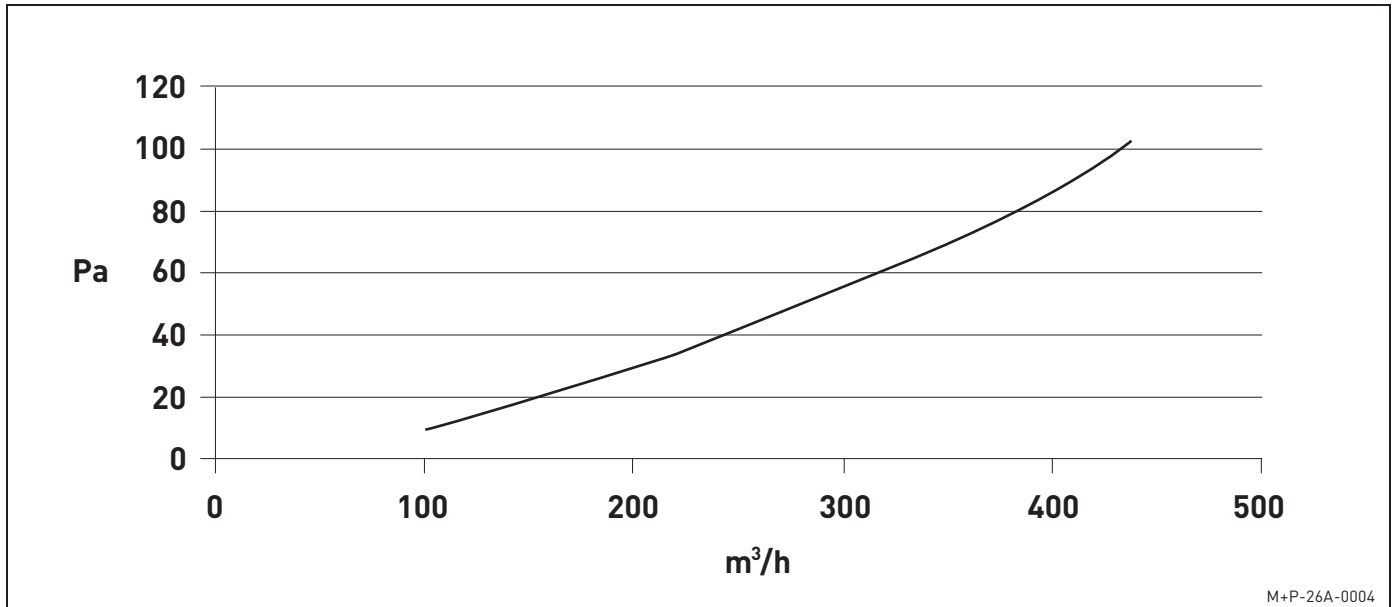

Pa Pressure drop

m³/h Flow rate



PLUGGIT

Immer frische Luft

10. COMPONENTS TO BE PROVIDED BY THE CUSTOMER

All components specified here are required to make sure the SWT180 works.

The required number of components may vary depending on the structural conditions.

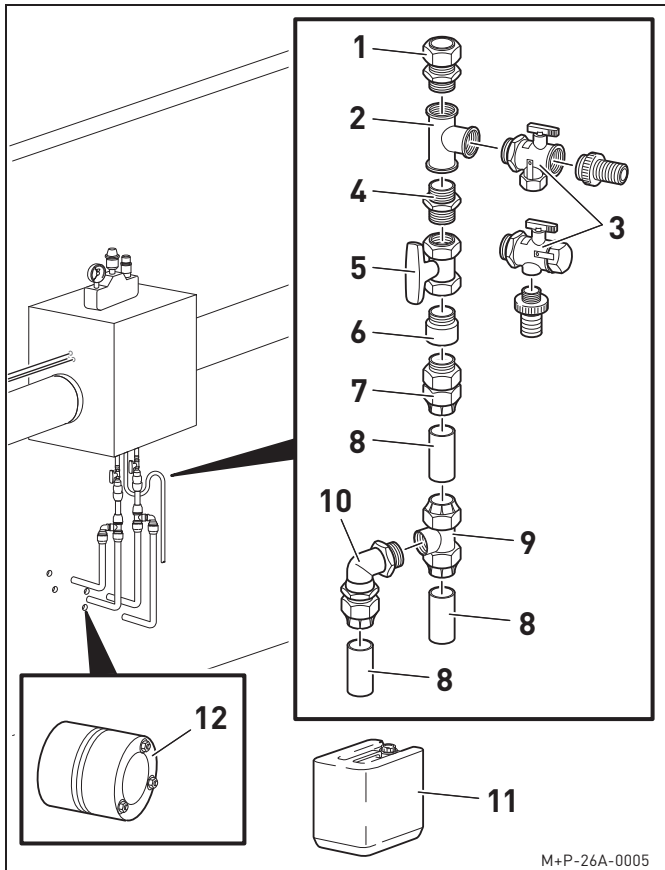

M+P-26A-0005

Pos.	Component	Description	Optional	Quantity
1	Clamping ring fitting ¹⁾	<ul style="list-style-type: none"> • 15 x 1/2" (SWT180 copper line connection of 15 x 1 mm) • Of brass • For mild steel, copper, stainless steel and cross-linked PE pipes • Suitable for concealed installation in accordance with DVGW TRGI 1986 • DVGW work sheet W534 in combination with CU pipes of 12 - 54 mm • DVGW work sheet W534 in combination with stainless pipes of 15 - 54 mm 	---	2
2	T-piece	<ul style="list-style-type: none"> • 1/2" • Bare red brass with 3 internal threads 	---	1



PLUGGIT

Immer frische Luft

Pos.	Component	Description	Optional	Quantity
3	Fill/drain ball valve	<ul style="list-style-type: none"> • ½" • With wing grip • Nickel-plated • Straight with hose fitting • Bend with hose fitting 	---	1
4	Hexagon fitting	<ul style="list-style-type: none"> • ½" • Bare red brass 	---	1
5	Heating ball valve	<ul style="list-style-type: none"> • DN 15 mm • Red brass PN 10 bar with ½" internal thread • 1x with gravity brake if necessary 	---	2
6	Reducer	<ul style="list-style-type: none"> • 1 x ½" • Bare red brass with external and internal thread 	---	2
7	Screw connection	<ul style="list-style-type: none"> • DN 32 mm with external thread (1") • PN 16 bar for water of 20 °C up to DN 63 mm • PN 12.5 bar for water of 20 °C from DN 75 mm • Also suitable for PEX pipes, with DVGW no. 	<ul style="list-style-type: none"> • Screw connection DN 32 mm, 90° with external thread (1") • PN 16 bar for water of 20 °C up to DN 63 mm • PN 12.5 bar for water of 20 °C from DN 75 mm • Also suitable for PEX pipes with DVGW no. 	2
8	PE-HD pipe	<ul style="list-style-type: none"> • 32 x 3 mm (corresponds to 1") • In compliance with DIN 8074/8075 • Black PE 80 • PN 12.5 bar/SDR 11 bar 	<ul style="list-style-type: none"> • PE-PEX pipes, 32 x 3 mm (corresponds to 1") of high-pressure cross-linked PE-HD PN 12.5 bar/SDR 11 bar for DIN/DVGW tested drinking water in accordance with DIN 16892/93 with blue PE coating 	2 x 50 m or 1 x 100 m
9	T-piece ²⁾	<ul style="list-style-type: none"> • DN 32 mm, 90° with internal thread (1") at central connecting piece • PN 16 bar for water of 20 °C up to DN 63 mm • PN 12.5 bar for water of 20 °C from DN 75 mm • Also suitable for PEX pipes, with DVGW no. 	---	2
10	Screw connection ²⁾	<ul style="list-style-type: none"> • DN 32 mm, 90° with external thread (1") • PN 16 bar for water of 20 °C up to DN 63 mm • PN 12.5 bar for water of 20 °C from DN 75 mm • Also suitable for PEX pipes, with DVGW no. 	---	2
11	Antifreeze	<ul style="list-style-type: none"> • E.g. Termera -35 °C • Biological and environmentally friendly antifreeze which can be used undiluted. 	<ul style="list-style-type: none"> • Use approved antifreeze for installation in earth. • Antifreeze concentrate of up to -18 °C, 20 litres 	60 litres
12	Wall duct	<ul style="list-style-type: none"> • For PE-HD pipe, DN 32 mm • Water-tight 	---	4

1) Press or solder fittings can also be used (15 x ½")

2) Not required for 1 x 100 m line length

The technology makes the difference.

Pluggit innovations with added value for the user and the environment.

2Q

Perfectly aligned cross-ventilation is created by the concealed installation of the air duct in the floor and ideal positioning of the air outlets. Displacement ventilation means the fresh air is fed into the room without draught and interference, without pressure and pre-heated in the cold months.

PluggMar®

Fresh air and heat supply in one – quicker, more flexible and more economic than customary heating systems.

allfloor

allfloor – in ceilings and walls, on or under concrete and screed – the Pluggit system concept provides maximum flexibility for the installation of air ducts and is as ideal for use in new buildings as it is for the refurbishment of existing buildings.

ServoFlow

The highly sensitive sensor and control system of this innovative technology enables the precise amount of fresh air required or desired to be supplied. The system adjusts itself to the cost-effective, time-saving system characteristics at the press of a button and automatically calibrates itself at regular intervals.

<EE>

Energy efficiency – a high heat recovery level on its own makes a ventilation system look effective and energy-efficient only at first glance. Decisive for the evaluation is rather the ratio between the energy applied and the heat recovery level achieved – referred to as electrical energy-efficiency. A high level of tightness, an economic design and state-of-the-art heat exchanger technology ensure excellent values for our ventilation systems in terms of heat recovery and energy efficiency.

CleanSafe

The CleanSafe principle ensures an almost impossible level of pollution of our distribution system due to technically smooth surfaces supplemented with a trouble-free cleaning concept, with convincing results confirmed by an independent testing institute.

refresh
by PLUGGIT

**How about fresh air in existing buildings?
The unique fresh air system for the energetic
refurbishment of existing buildings.**

How about fresh air? You can obtain more information on the company, on the intelligent technology of Pluggit fresh-air systems, on references and regional contacts at www.pluggit.com or as dialogue at www.lueftungsblog.de

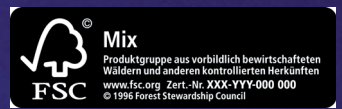

IA SWT 180/V01 02.2009



How about fresh air?

Pluggit GmbH | Wamslerstr. 2 | 81829 München, Germany | Telephone +49 (0)89 35 77 31-0 | Fax +49 (0)89 35 77 31-79
www.pluggit.com | www.lueftungsblog.de

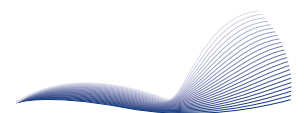

PLUGGIT

Immer frische Luft